

JENNY SCIENCE

moving precisely, within tight space

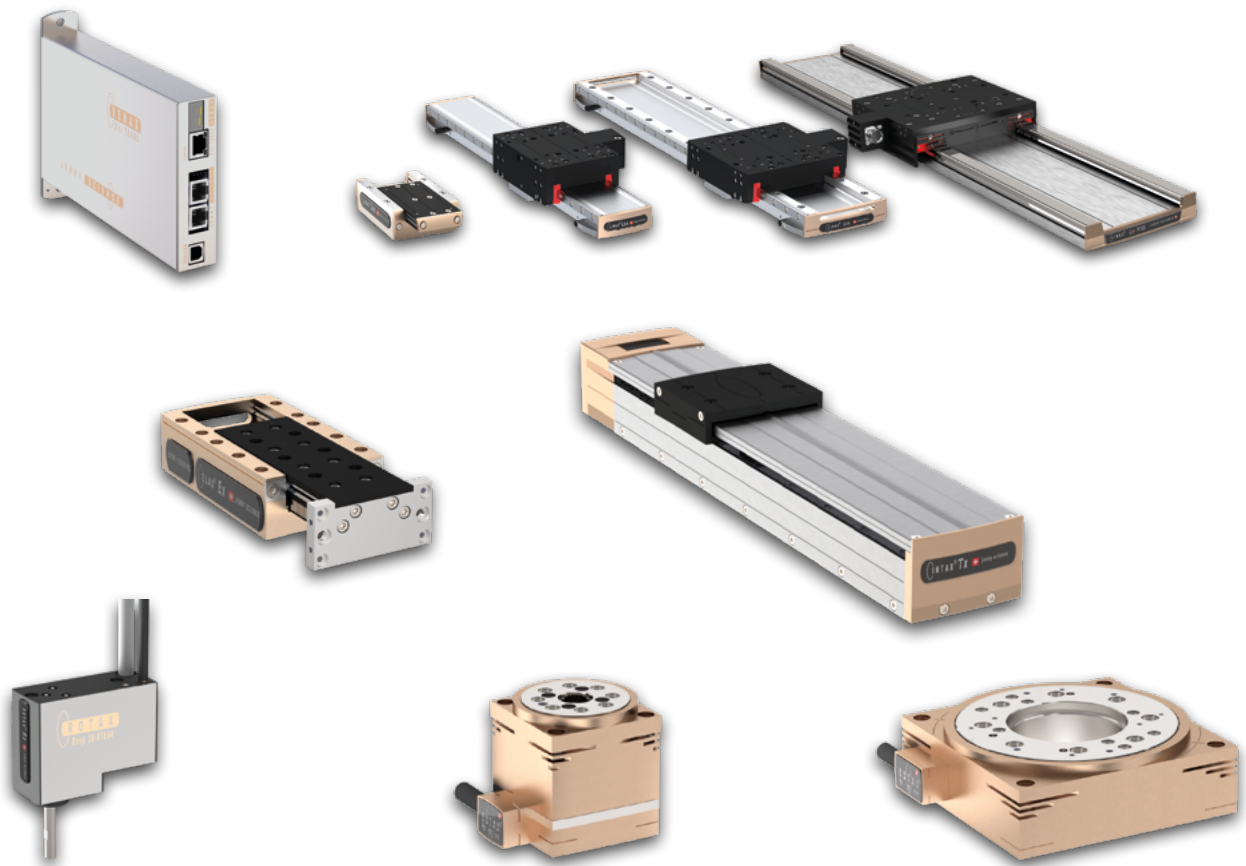

Compact linear motor axes, new with integrated servo controller, hollow shaft motors and intelligent, web-based servo controllers

Jenny Science – a success story

As an ambitious, international family business, Jenny Science is today a leading component manufacturer for industrial automation. With over 60 employees at its headquarters in Rain, Switzerland, we design and manufacture compact linear motor axes, electric linear motor slides, hollow shaft servo motors and intelligent, web-based servo controllers for automation customers around the world.



2022 «GO» and the axis runs!

INTAX®, the world's first linear motor axis with integrated servo drive; everything runs automatically: Simply connect the USB-C cable and enter «run.Webmotion» in Windows Explorer to open WebMotion®. Click on «GO» and the axis runs.



2015 IHZ Innovation Award for Forceteq®

Jenny Science was selected for the IHZ Innovation Award for the Forceteq® force measuring technology, which senses forces in linear motor axes; executing movements and simultaneously monitoring them.



1998 Winner of Technology Location Switzerland for JENYTEC®

The ultra-compact and multi-functional JENYTEC® servo controllers are distinguished by the Technology Location panel of Switzerland. The product was selected for its compact construction and innovative content.

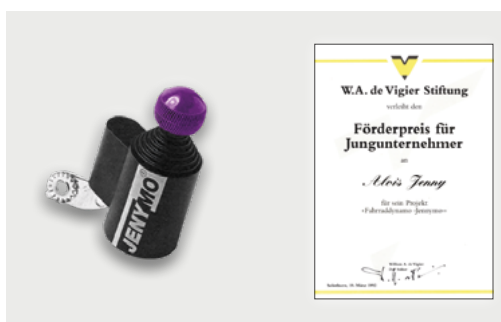

1994 De Vigier Award for JENYMO®

Founder Alois Jenny wins the W.A. de Vigier Foundation sponsorship award for the world's first bicycle dynamo with integrated stand still light. The JENYMO® bicycle dynamo has fully integrated stand still light electronics and a rechargeable battery.

Various drive types for linear movements in comparison

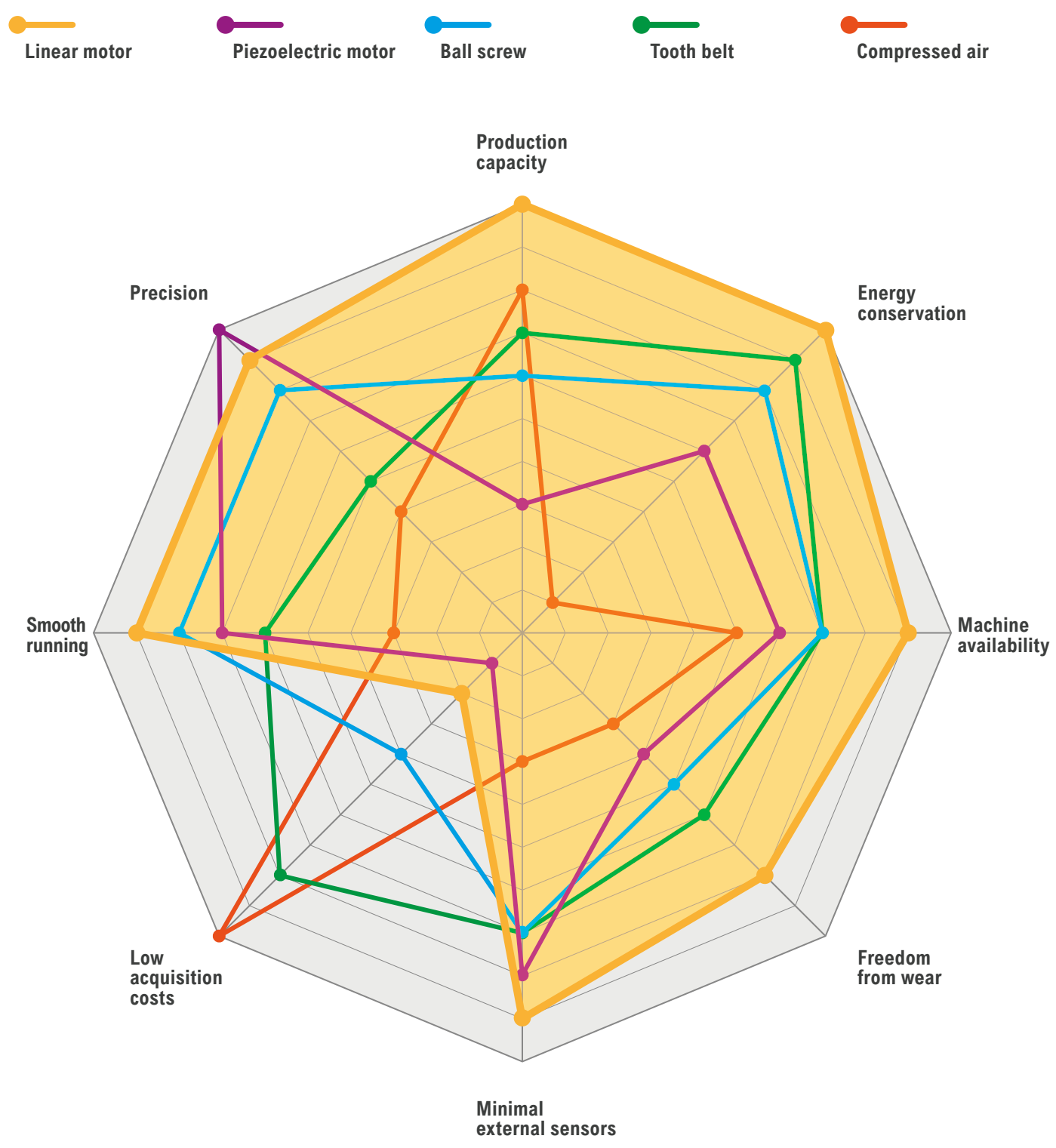

Specific advantages of linear motor axes from Jenny Science

Compact dimensions and lightweight construction

This allows you to build your machines smaller, saving space, specifically at the INTAX® linear motor axis with integrated servo controller and achieving higher productivity within the same production area. For longer travel distances, the installation space required for Jenny Science linear motor axes is extremely small in relation to the travel distance. With the lightweight design, less idling mass is set in motion. This means shorter cycle times, less vibration, less noise and less energy consumption.

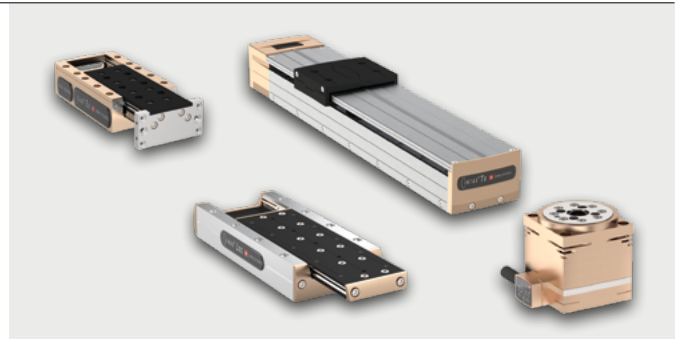

Modular construction kit for your standardization

Our flexible modular system is absolutely unique to the market. With universal drive components from Jenny Science, you can build your machines more compact, with less effort and in less time. This reduces the costs of development, commissioning and accessories are easy to incorporate into your design.



Web browser operating menu

Simply enter the IP address in your web browser and Web-Motion® is ready for operation. No application needs to be installed on your laptop or PC and no registration is required. Commissioning a servo axis has never been easier.



Forceteq® force measurement technology

Forceteq® basic, is current-based and completely integrated in the XENAX® servo controller. The force is measured via the automatically calibrated motor current without a force sensor. Forceteq® pro, works with Signateq® measuring amplifier and commercial available DMS force sensor. The force value is transferred directly to the XENAX® servo controller. An external evaluation electronics box is not required.

- Force-stroke diagram with monitoring
- Force limitation
- Power pre-control



PLC bus communication

Easy integration of the market-leading Ethernet bus protocols such as EtherCAT, Profinet, Ethernet/IP, Powerlink and CANopen. With the supplied libraries, your machine programmers can work in the familiar development environment of the PLC and do not need any special knowledge. Furthermore, a complete ASCII command set is also available to operate the axes via the standard TCIP/IP socket or via COM interface.

EtherCAT

EtherNet/IP

CANopen

PROFINET
IRT (isochrone Real Time)

Ethernet TCP/IP

ETHERNET POWERLINK

Automatic motor recognition

All Jenny Science linear and rotary axes are automatically recognized and parameterized by the XENAX® Servocontroller. Commissioning, testing and fine tuning are then performed using the intuitive, HTML 5-based WebMotion® operating menu and web browser. The programming for a possible «stand alone operation» is also carried out via web browser.

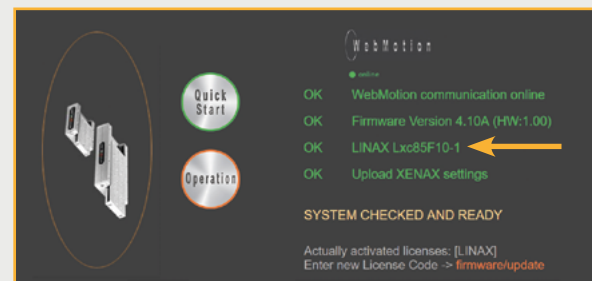

Functional safety: SIL 2, PL d, Cat. 3

To guarantee the functional safety of the direct drive axes, the XENAX® Xvi 75V8S servo controller can be equipped with the Safety Motion Unit (SMU). This makes the various TÜV-certified safety functions STO, SS1, SS2 and SLS available. Furthermore, the axes can also be supplied in a UL certified version.



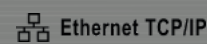

XENAX® Xvi Servo controller

Xvi 75V8S · Xvi 48V8

- easy commissioning and programming with WebMotion® via any HTML5 web browser.
- automatic recognition and parameterization of JSc linear motor axes and servo motors
- High-end control technology with continuous transition from position control to force control and vice versa .
- Interfaces and libraries for modern PLC Ethernet bus protocols .
- Safety functionalities certified according to TÜV, UL certified versions .
- Compact and everything inside: Safety, Web server, TCP/IP, Ethernet fieldbus modules, Master-Slave

Patented force monitoring Forceteq® basic (current-based) and Forceteq® pro (with strain gauge sensor)

Integrated web server with WebMotion® operator menu via HTML5 web browser

Position controller <-> force controller, S-curve trajectory generator

Xvi 75V8S: 12 digital inputs and 8 outputs with 24V

Xvi 48V8: 4 digital inputs and 2 outputs with 24V

Fully programmable for stand-alone handling operations with Lead and Follower function up to 4 axes

Xvi 75V8S: separate power inputs for Logic (24V) and Power Stage (24V–75V)

Xvi 48V8: separate power inputs for Logic (24V) and Power Stage (24V–48V)

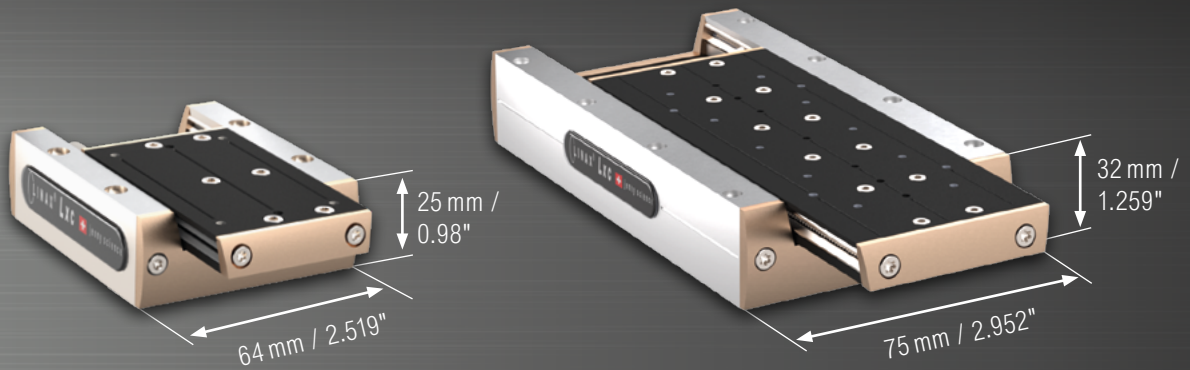

LINAX[®] Lxc Linear motor axes

Lxc = compact

- patented monoblock construction
- no cables moving
- excellent performance/volume ratio
- safety integrity Level 2, PL d, CAT. 3 together with XENAX[®] servo drive

LINAX [®]	Position Accuracy	
Lxc	optical 100nm	optical 1µm
	+/- 400nm	+/- 1.5µm

LINAX [®]	Stroke [mm] (in)	L Install. [mm] (in)	Force Fn / Fp [N] (lbf)	Weight Slider/Total [g] (lbs)
Lxc 44F08 ¹⁾	44 (1.73)	78 (3.07)	08/24 (1.79/5.39)	130/350 (0.28/0.77)
Lxc 85F10 ¹⁾	85 (3.34)	144 (5.66)	10/30 (2.24/6.74)	230/650 (0.50/1.43)
Lxc 135F10	135 (5.31)	194 (7.63)	10/30 (2.24/6.74)	320/880 (0.70/1.94)
Lxc 230F10	230 (9.05)	290 (11.41)	10/30 (2.24/6.74)	450/1200 (0.99/2.64)
Lxc 80F40 ¹⁾	80 (3.14)	169 (6.65)	40/114 (8.99/25.62)	520/1470 (1.14/3.24)
Lxc 176F40 ¹⁾	176 (6.92)	265 (10.43)	40/114 (8.99/25.62)	750/2150 (1.65/4.73)
Lxc 272F40	272 (10.70)	361 (14.21)	40/114 (8.99/25.62)	1050/2800 (2.31/6.17)

1) available with weight compensation of up to 3 kg (6.61 lbs)/6 kg (13.22 lbs)

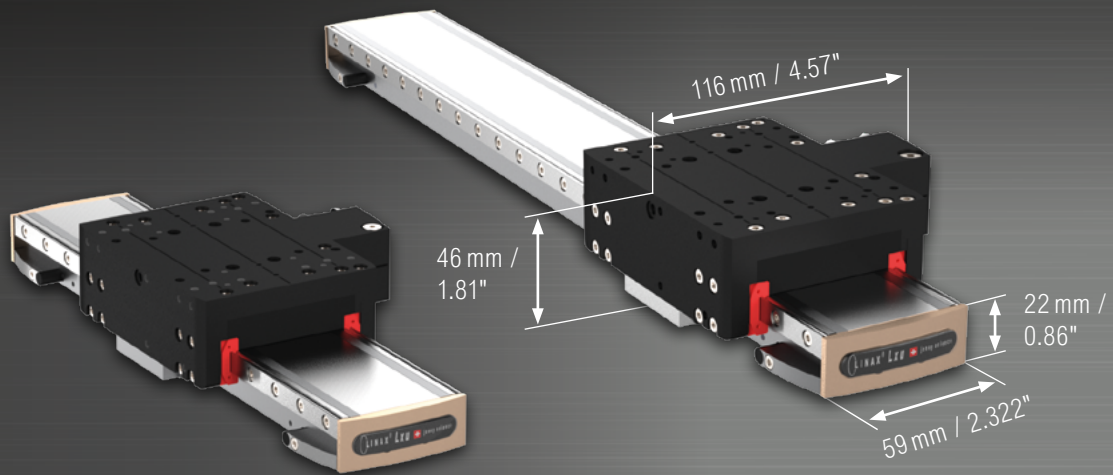

LINAX® Lxu Linear motor axes

Lxu = universal

- 3 installation options: carriage/ground plate/front flange
- 4 through holes for flexible installation
- safety Integrity Level 2, PL d, CAT. 3 together with XENAX® servo controller

LINAX®	Force Fn / Fp [N] (lbf)	Weight Carriage [g] (lbs)	Position Accuracy			
			optical 100nm	optical 1µm	magnetic 1µm	
Lxu	60 / 180 (13.48 / 40.46)	950 (2.09)	+/- 500nm	+/- 2µm	+/- 5µm	

LINAX®	Stroke [mm] (in)	L Install. [mm] (in)	Weight Total [g] (lbs)
Lxu 40F60 ¹⁾	40 (1.57)	170 (6.69)	1700 (3.74)
Lxu 80F60 ¹⁾	80 (3.14)	210 (8.26)	1900 (4.18)
Lxu 160F60 ¹⁾	160 (6.29)	290 (11.41)	2200 (4.85)
Lxu 240F60	240 (9.44)	370 (14.56)	2600 (5.73)
Lxu 320F60	320 (12.59)	450 (17.71)	2900 (6.39)

¹⁾ available with weight compensation of up to 6 kg (13.22 lbs)

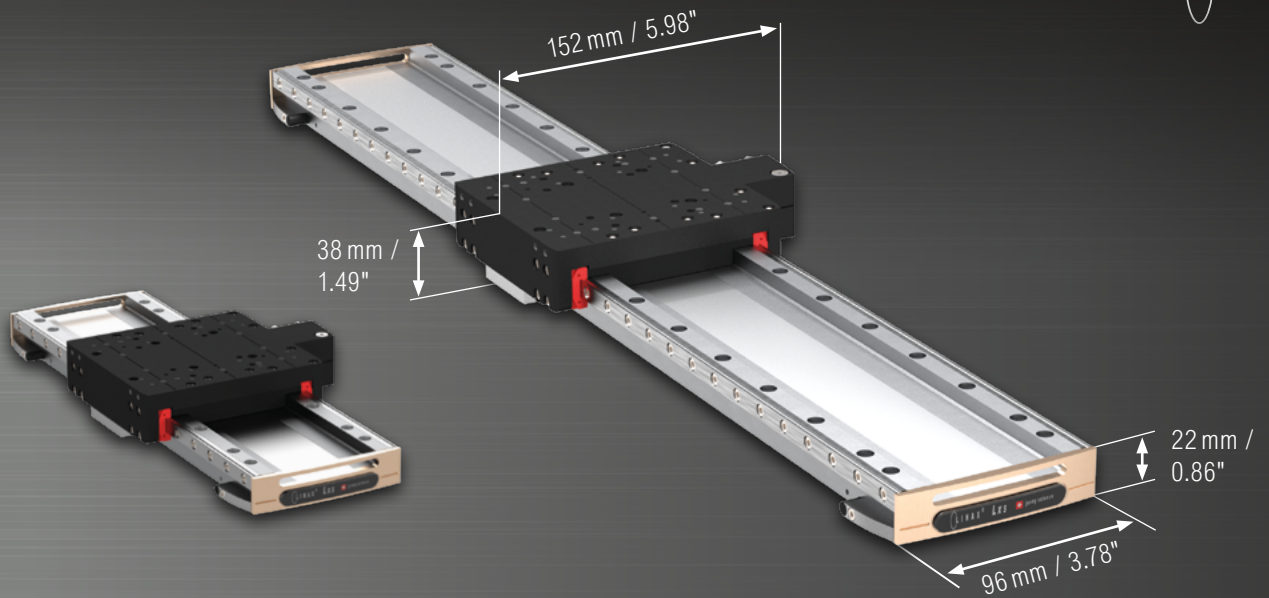

LINAX® Lxs F60 Linear motor axes

Lxs = shuttle

- long strokes up to 1600 mm (62.99 in)
- small height of only 38 mm (1.49 in)
- wide spaced linear guides for high loads
- safety Integrity Level 2, PL d, CAT. 3 together with XENAX® servo controller

LINAX®	Force Fn / Fp [N] (lbf)	Weight Carriage [g] (lbs)	Position Accuracy			
			optical 100nm	optical 1µm	magnetic 1µm	
Lxs F60	60 / 180 (13.48 / 40.46)	1000 (2.20)	+/- 500nm	+/- 2µm	+/- 5µm	

LINAX®	Stroke [mm] (in)	L Install. [mm] (in)	Weight Total [g] (lbs)
Lxs 160F60	160 (6.29)	290 (7.48)	2600 (5.73)
Lxs 200F60	200 (7.87)	330 (12.99)	2800 (6.17)
Lxs 320F60	320 (12.59)	450 (17.71)	3400 (7.49)
Lxs 400F60	400 (15.74)	530 (20.86)	3900 (8.59)
Lxs 520F60	520 (20.47)	650 (25.59)	4500 (9.92)
Lxs 600F60	600 (23.62)	730 (28.74)	5000 (11.02)
Lxs 800F60	800 (31.49)	930 (36.61)	6000 (13.22)
Lxs 1000F60	1000 (39.37)	1130 (44.48)	7200 (15.87)
Lxs 1200F60	1200 (47.24)	1330 (52.36)	8400 (18.51)
Lxs 1600F60 ¹⁾	1600 (62.99)	1730 (68.11)	10800 (23.80)

¹⁾ only available with magnetic measuring system

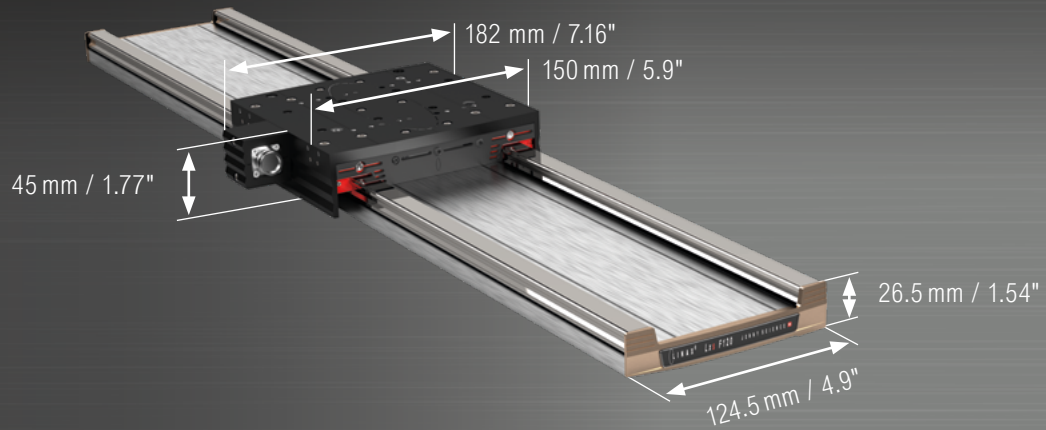

LINAX® Lxs F120 Linear motor axes

Lxs = shuttle

- long strokes up to 1600 mm (62.99 in)
- innovative one-cable solution
- absolute measurement system
- the possibility of using multiple slides

LINAX®	Force Fn / Fp [N] (lbf)	Weight Carriage [g] (lbs)	Position Accuracy			
			optical 100nm	optical 1µm	magnetic 1µm	
Lxs F120	120 / 300 (27.0 / 67.4)	2300 (5.07)	+/- 500nm	+/- 2µm	+/- 4µm	

LINAX®	Stroke [mm] (in)	L Install. [mm] (in)	Weight Total [g] (lbs)
Lxs 080F120	80 (3.15)	243 (9.57)	4700 (10.36)
Lxs 200F120	200 (7.87)	363 (14.29)	5900 (13.00)
Lxs 400F120	400 (15.75)	563 (22.17)	7800 (17.20)
Lxs 520F120	520 (20.47)	683 (26.89)	9000 (19.84)
Lxs 600F120	600 (23.62)	763 (30.04)	9800 (21.61)
Lxs 800F120	800 (31.50)	963 (37.91)	11800 (26.01)
Lxs 1000F120	1000 (39.37)	1163 (45.79)	13700 (30.20)
Lxs 1200F120	1200 (47.24)	1363 (53.66)	15700 (34.61)
Lxs 1600F120	1600 (62.99)	1763 (69.41)	19600 (43.21)

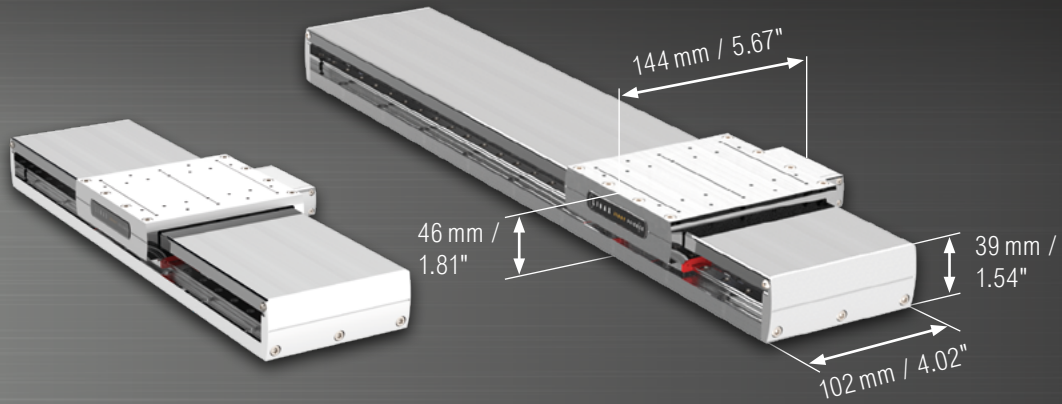

LINAX[®] Lxe Linear motor axes

Lxe = exclusive

- protection cover under the carriage
- easy cleaning
- suitable for medical and semiconductor applications
- safety Integrity Level 2, PL d, CAT. 3 together with XENAX[®] servo drive

LINAX [®]	Force Fn / Fp [N] (lbf)	Weight Carriage [g] (lbs)	Position Accuracy	
			Lxe	40 / 114 (8.99 / 25.62)

LINAX [®]	Stroke [mm] (in)	L Install. [mm] (in)	Weight Total [g] (lbs)
Lxe 250F40	250 (9.84)	386 (15.19)	3080 (6.79)
Lxe 400F40	400 (15.74)	536 (21.10)	3850 (8.48)
Lxe 550F40	550 (21.65)	686 (27.00)	4620 (10.18)
Lxe 800F40	800 (31.49)	936 (36.85)	5900 (13.00)
Lxe 1000F40	1000 (39.37)	1136 (44.72)	6930 (15.27)

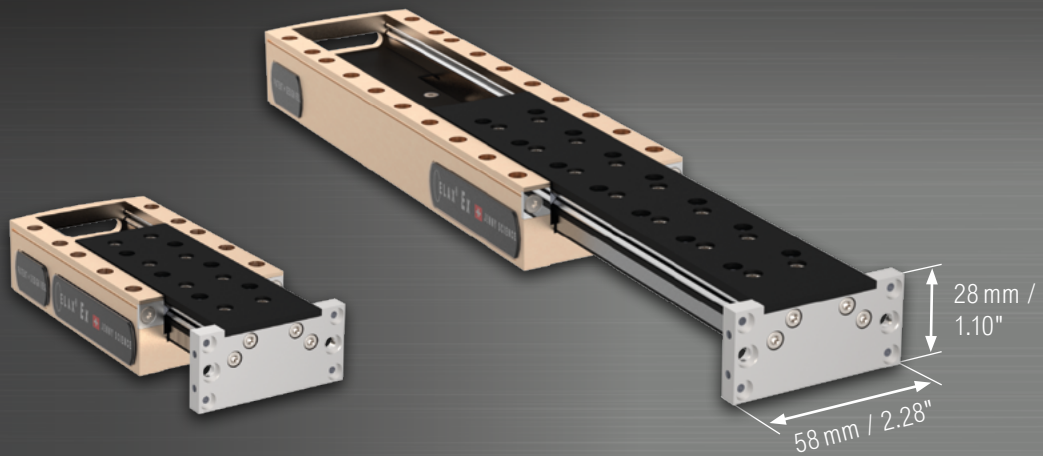

ELAX[®] Ex Electric slides

ELAX[®] Ex

- Electric slides for fast, precise pick and place units
- modular design with direct fitting of axes on the front flange
- single cable solution
- Safety integrity level 2, PL d, Cat. 3 using XENAX[®] servo controller

ELAX [®]	Force Fn/Fp [N] (lbf)	Position Accuracy
Ex	20/60 (4.49/13.48)	+/- 5µm

ELAX [®]	Stroke [mm] (in)	L Install. min/max [mm] (in)	Weight Slider/ Total [g] (lbs)
Ex 30F20 ¹⁾	30 (1.18)	110/140 (4.33/5.51)	195/560 (0.42/1.23)
Ex 50F20 ¹⁾	50 (1.96)	130/180 (5.11/7.08)	265/630 (0.58/1.38)
Ex 80F20 ¹⁾	80 (3.14)	178/258 (7.00/10.15)	340/780 (0.74/1.71)
Ex 110F20 ¹⁾	110 (4.33)	208/318 (8.18/12.51)	415/945 (0.91/2.08)
Ex 150F20	150 (5.90)	268/418 (10.55/16.45)	490/1110 (1.08/2.44)

1) available with weight compensation of up to 2 kg (4.40 lbs)

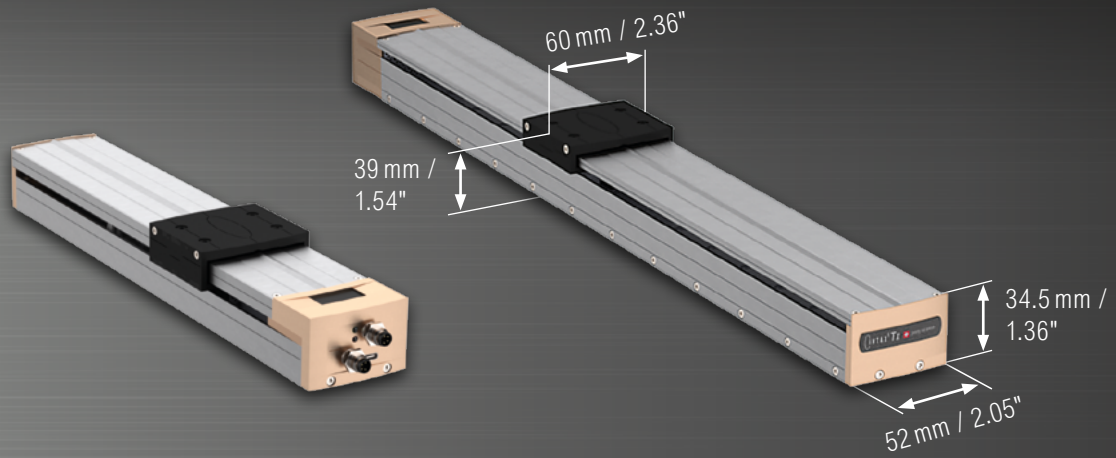

INTAX[®] Tx Linear motor axis

INTAX[®] = integrated Axis

- integrated servodrive, motor wiring and cable chain
- Two connectors only, one for Ethernet Bus and the other for 24V – 36V DC-Power
- Absolute measurement system with 1µm resolution, no reference drive necessary
- No space is required in the control cabinet

INTAX [®]	Force Fn / Fp [N] (lbf)	Encoder absolute	Dimensions Carriage W x H [mm] (in)	Weight Carriage (g)	Repetition Accuracy
Tx	8 / 24 (1.80 / 5.40)	1µm abs.	60 x 39 (2.36 x 1.54)	170	+/- 2µm

INTAX [®]	Stroke [mm] (in)	L Install. [mm] (in)	Weight Total [g] (lbs)
Tx 50F08	50 (1.97)	149 (5.87)	425 (0.94)
Tx 100F08	100 (3.94)	201 (7.91)	550 (1.21)
Tx 200F08	200 (7.87)	299 (11.77)	800 (1.76)
Tx 400F08	400 (15.75)	500 (19.69)	1300 (2.87)
Tx 600F08	600 (23.62)	700 (27.56)	1800 (3.97)



«GO» and the axis runs!

Everything runs automatically:
 Simply connect the USB-C cable and a virtual network adapter is created on the PC/laptop. And by entering «run.Webmotion» in Windows Explorer, the web browser opens with WebMotion®. Button Quick Start, click on «GO» and the axis is running. No download, no installation of an app, no purchase of a license code and no registration, very user friendly.

What's behind it?

The decisive factor is the integrated servo controller with web server and the WebMotion® graphical user interface. This HTML5-based operator interface can be accessed via any web browser.

For professional machine integration, the axis offers fully developed Ethernet fieldbus communication with various protocols. The fieldbus connector provides a direct connection to the PLC, where currently the EtherCAT, Ethernet I/P and Profinet protocols are supported, more will follow.

Together with the library, similarly to PLCopen®, the axis can be put into operation immediately in cyclic synchronized mode or in profile position mode. The linear measuring system with absolute position allows an immediate start, without prior referencing to a zero point.

With connection to the 24VDC supply, the axis is directly ready for operation. The power supply is separate for controller and power output stage. This means that STO is already included as a functional safety feature. If the power output stage is interrupted, communication is maintained.

Integrated force control with Forceteq® basic A milestone of miniaturization

With the well-known Forceteq® basic force measurement of the servo controller, the cogging, load and friction forces of the iron-core linear motor can be compensated via the patented calibration method. This compensation is done by an automatically running calibration process (Force Calibration) of the completely installed axis with its configuration.

The calibration can be restarted at any time if load force, friction or orientation of the axis should change. To increase the accuracy of the recorded forces, the temperature drift is also compensated for when the output stage heats up.

With this Forceteq® basic, quality-relevant force-displacement diagrams can be recorded during travel. Assembly processes are thus monitored «in-process» and are traceable. It is also possible to move «by force», e.g. to press electrical contact adapters onto printed circuit boards with a specific force. This force-controlled contacting is used, for example, for reliable programming of the firmware on the hardware.

The INTAX® linear motor axis pushes the boundaries of miniaturization and shows what is technologically feasible today. The idea of physically building the servo controller into a motor axis is not new, and there are some servo motor suppliers that build the motion controller in directly. For linear motor axes, the INTAX® is the only solution available on the market with a fully integrated servo controller.

The INTAX® linear motor axes were specifically designed for miniaturization to integrate the electronic boards, motor wiring and cable trailing into the «free space» of the mechanical design. For this reason, the design of the axis was redesigned and the electronics were extremely compressed and distributed on different PCBs.

It is not visible from the outside where the servo controller is located. This results in an incredibly compact design with a slim, clear geometric shape. This allows engineers to build their machines and systems smaller and more space-efficient. Wiring, connectors and space for a servo controller are no longer required. And compared to conventional toothed belt and spindle drives, the INTAX® linear motor direct drive is more precise, faster and quieter.

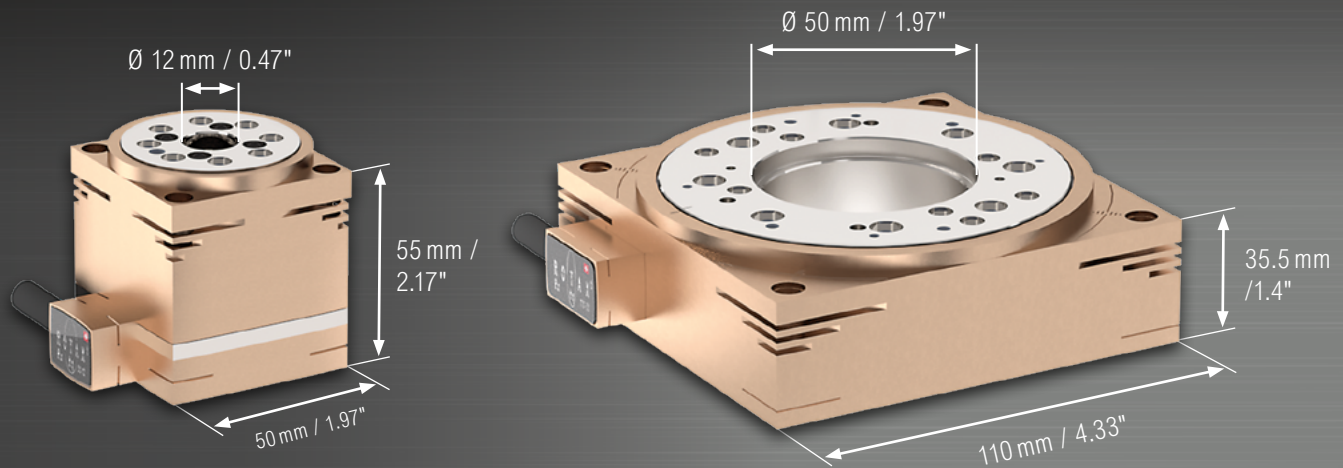

ROTAX® Rxhq Rotary motor axes

Rxhq = high torque

- ultra compact dimensions
- extra large through hollow shaft
- high torque motor – no gear
- integrated absolute encoder
- Multiturn with XENAX® Xvi 75V8S
- Safety integrity level 2, PL d, Cat. 3 using XENAX® servo controller

ROTAX®	Position Accuracy	
	Unidirect.	Biddirect.
Rxhq	+/- 7arc-sec	+/- 11arc-sec

ROTAX®	Encoder absolute [inc/rev]	Vmax 24V [rpm]	Vmax 48V [rpm]	Wiring	Torque Mn / Mp [Nm] (lbf in)
Rxhq 50-12T0.3	120000	1200	2400	One cable connection	0.3 / 1.02 (2.66 / 9.03)
Rxhq 110-50T1.5	120000	300	600	One cable connection	1.5 / 4.0 (13.28 / 37.17)

ROTAX®	Length [mm] (in)	Dimensions W x H [mm] (in)	Hollow shaft opening [mm] (in)	Weight [g] (lbs)
Rxhq 50-12T0.3	50 (1.97)	50 x 55 (1.97 x 2.17)	12 (0.47)	440 (0.97)
Rxhq 110-50T1.5	110 (4.33)	110 x 35.5 (4.33 x 1.4)	50 (1.97)	1200 (2.65)

ROTAX® RXHQ 50

The new, self-developed miniature hollow shaft servo motor ROTAX® Rxhq (high torque) impresses with its extremely compact design of 50 x 50 x 55mm / 1.96 x 1.96 x 2.16". Direct drive motor, precise bearings and the single turn absolute encoder are completely integrated.

The direct drive servo motor is based on the magnetic flux technology of wind turbine generators. This generates a high torque at low speed. In figures this means a factor 2-3 higher torque with the same construction volume compared to a conventional direct drive of competitors.

The large hollow shaft with a diameter of 12mm / 0.47" offers generous space for cables, vacuum or compressed air lines, light and laser beams, glass fibres and other media. Another advantage in this context is the short overall length of only 55mm incl. built-in encoder. The connection cable consists of only one cable and offers advantages in the space required for cable installation. Thanks to the precise, precompressed double bearing on the front flange, the drive achieves high rigidity with high axial torque capacity.

ROTAX® RXHQ 110

The direct drive developed in-house impresses with its flat design, compact external dimensions and a hollow shaft with a diameter of 50mm. Cables, vacuum or compressed air lines, light and laser beams, glass fibers or camera lenses can thus be easily guided through the hollow shaft.

The absolute measuring system allows an immediate start without previous referencing. With a resolution of 120.000 inc. per revolution, repeatability of ± 11 arcsec can be achieved. The single-cable connection can be supplied in right-hand or left-hand output configuration.

Together with the patented «Force Calibration» function, undesired cogging, weight and friction forces of the ROTAX® Rxhq direct drives can be easily compensated. This makes it possible to specify, limit and monitor forces in processes. Together with the Forceteq® basic technology included in the XENAX® servo controller, complete force/distance diagrams can be recorded - an additional torque sensor is not necessary.

Specific advantages

- Ultra compact dimensions
- Oversized continuous hollow shaft
- High torque - no gearbox
- Integrated absolute encoder system
- Single cable connection

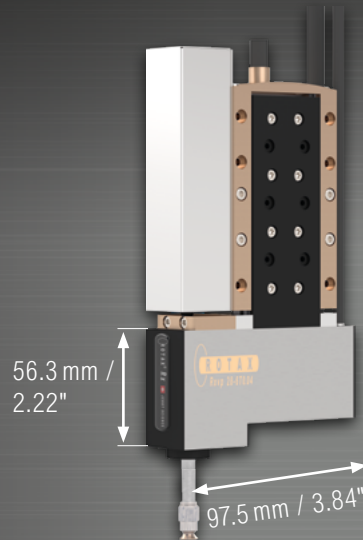
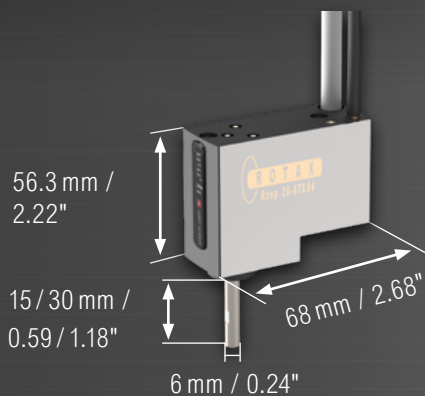

ROTAX® Rxvp Rotary motor axes

Rxvp = vacuum pressure

- Rotary motor axis with vacuum/compressed air feedthrough
- direct mounting on the ELAX® front flange
- high level of accuracy and robustness
- single cable solution

ROTAX®	Position Accuracy	
Rxvp	Unidirect.	Bidirect.
	+/- 12arc-sec	+/- 20arc-sec

ROTAX®	Vmax [rpm]	Torque Mn/Mp [Nm] (lbf in)	Encoder incremental	Wiring
Rxvp 28-6T0.04	1500	40/110 (0.35/0.97)	64000 Inc/rev 360° endless rot.	One cable connection

ROTAX®	Shaft [mm] (in)	Length [mm] (in)	Dimensions W x H [mm] (in)	Weight Total Shaft 15/30mm (0.59/1.18 in) [g] (lbs)
Rxvp 28-6T0.04	∅ 6 x 15/∅ 6 x 30 (∅ 0.24 x 0.59/∅ 0.24 x 1.18)	68 (2.68)	27.5 x 56.3 (1.08 x 2.22)	325/330 (0.71/0.72)
Rxvp 28-6T0.04 ¹⁾	∅ 6 x 15/∅ 6 x 30 (∅ 0.24 x 0.59/∅ 0.24 x 1.18)	97.5 (3.84)	27.5 x 56.3 (1.08 x 2.22)	345/350 (0.76/0.77)

1) longer version for fitting to an ELAX® Ex F20 axis with weight compensation



Safety Motion Unit (SMU)

The optional SMU module extends the XENAX® Xvi 75V8S servo controller by TÜV certified safety functions (Safety Integrity Level 2, PL d, Cat. 3). The SMU modules are mounted and tested strictly in accordance with TÜV specifications, so that all safety functions can be guaranteed.

STO: Safe Torque Off

The STO function is the most common and basic drive-integrated safety function. It ensures that no torque-generating energy can continue to act upon a motor.

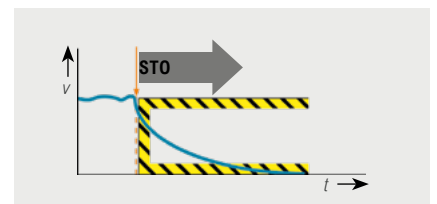

SS1: Safe Stop 1

The SS1 function causes a motor to stop rapidly and safely and switches the motor to exert no torque at all after coming to a standstill, i.e. STO is activated.

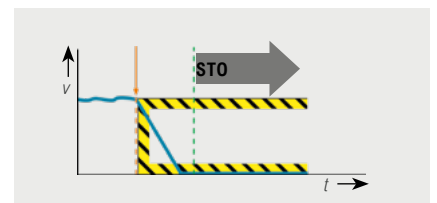

SS2: Safe Stop 2

The SS2 function shuts down a motor quickly and safely and then activates the SOS function after coming to a standstill. With the SOS function, the stopped motor is brought into position and monitored by a drive control.

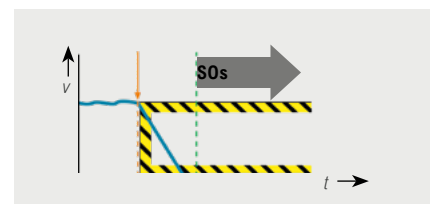

SLS: Safely-Limited Speed

The SLS function ensures that the drive does not exceed a defined speed limit.

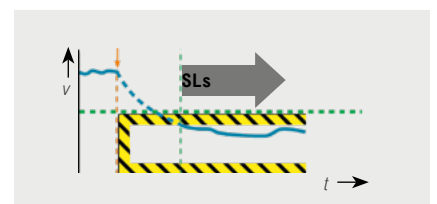

PLC Bus communication

The XENAX® Xvi servo controllers can be operated via bus module with all market-leading PLC controls in real time. Libraries with application examples are available for the two practice-relevant operating modes, «profile positioning mode» and «cyclic synchronized positioning mode».

Programmable Logic Controller (PLC)

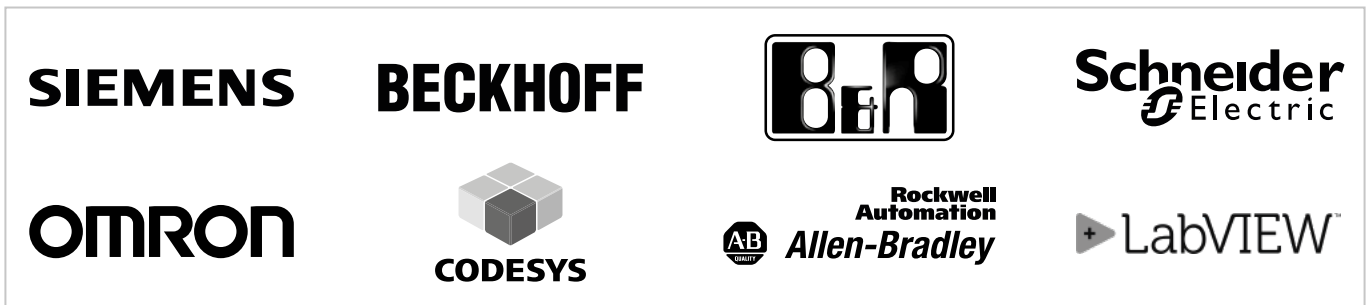

Bus Systems



Servo Drives

Integrated Linear Motor



Linear/ Rotary motor axes

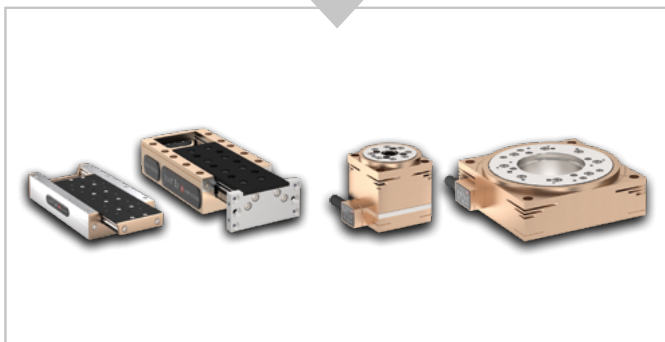



Fraunhofer
TESTED[®]
DEVICE
 Jenny Science AG
 Linax Lx 85F10R
 Report No. JE 0910-497

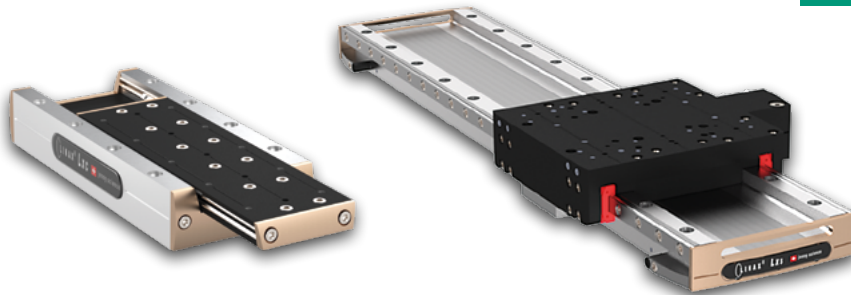

LINAX[®] Linear motor axes in clean room standards

Cleanroom conditions according to ISO 14644-1

- assembly is completed in a certified cleanroom (Class 7)
- type of airflow: non laminar flow

LINAX [®] Linear motor axes (cross roll guides)	Slow	Typical	Fast
Velocity (m/s)	0.1	0.5	2.0
Accelerance (m/s ²)	1.0	10.0	20.0
Air Cleanliness Class (according to ISO 14644-1)	3	5	5

LINAX [®] Linear motor axes (recirculating ball bearing guides)	Slow	Typical	Fast
Velocity (m/s)	0.1	0.5	2.0
Accelerance (m/s ²)	1.0	10.0	20.0
Air Cleanliness Class (according to ISO 14644-1)	4	4	5

Forceteq[®] basic



Current based with self calibrated motor

The Forceteq[®] basic measurement technology is completely integrated in the XENAX[®] Xvi servo controller. This allows force-monitored control of all Jenny Science linear and rotary motor axes. The force measured during the production process using the patented Forceteq[®] measurement technology, no external force sensor is required. This allows you to acquire and record quality-relevant force-distance diagrams for all movements. Assembly operations can be monitored «in process». Errors and discrepancies are detected immediately. This means better quality and higher throughput. Additional checking stations are no longer necessary.

- for Standalone Operation
- Up to 10 force sectors programmable with WebMotion[®]

Forceteq[®] pro with Signateq[®] measuring amplifier

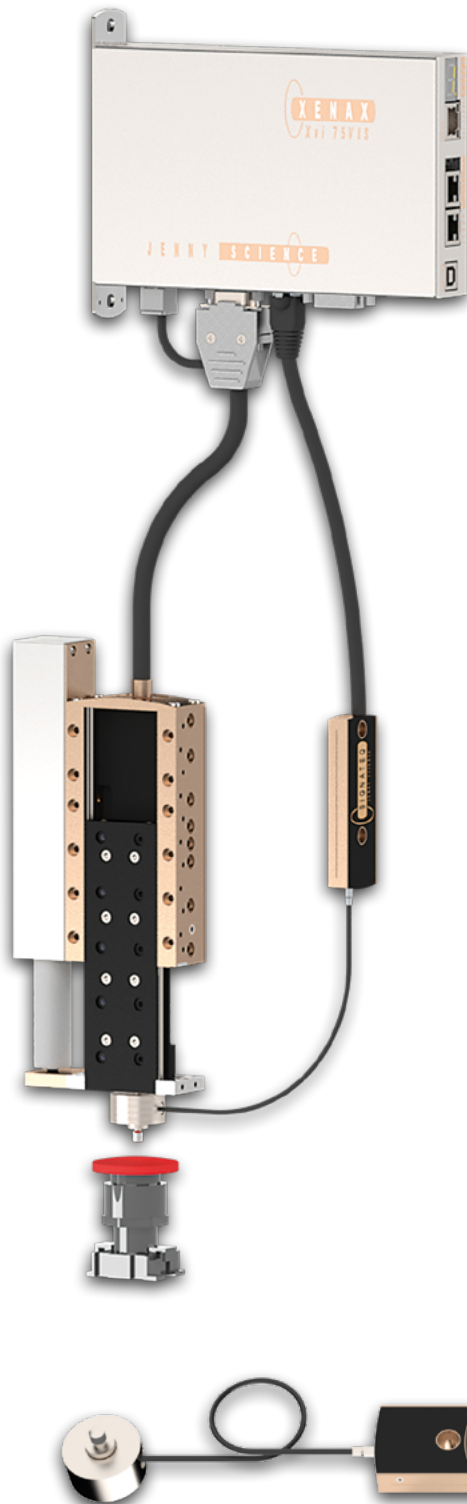

Connect DMS load cell, set sensitivity, that's all!

With Forceteq[®] pro you can very easily integrate a commercially available DMS load cell from Burster, Kistler or Futek into your application. With the sensor you typically also receive a test report with the value of the sensitivity in [$\mu\text{V}/\text{V}$]. This value is individual for each sensor.

Precise force measurement has never been easier

First connect the 4 wires of the DMS load cell to the Signateq[®] measuring amplifier (solder). The Signateq[®] measurement amplifier is connected to the XENAX Xvi 75V8S servo drive. In the menu «Load Cell» the value of the sensitivity of the force sensor can be entered. Because of the very good linearity of DMS load cells, you can achieve an accuracy of $\leq 0.5\%$ over the complete load range of the sensor. Typically, calibration of the measuring range is no longer necessary. To be on the safe side, you can verify the forces very easily with a commercial weigh scale.

The force value is now directly available in the XENAX[®] servo controller and does not have to be transmitted by external control electronics. This enables the shortest cycle times. In addition, the external control electronics can be saved.

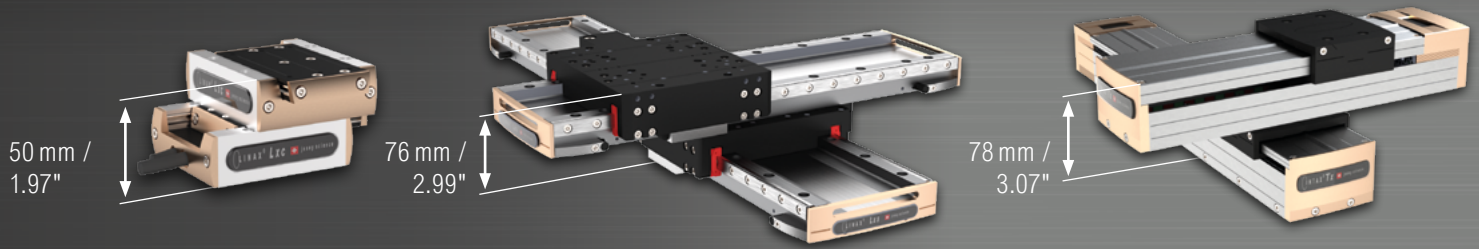

X-Y Cross table

LINAX® Lxs · LINAX® Lxc

- extremely low overall height
- flatness of the whole area measurable and adjustable to $<10\ \mu\text{m}$

Arrangement	Axes	Function
X-Y LINAX®	1 × LINAX® Lxc 44F08 1 × LINAX® Lxc 44F08	X-axis Y-axis
X-Y LINAX®	1 × LINAX® Lxs 400F60 1 × LINAX® Lxs 320F60	X-axis Y-axis
X-Y INTAX®	1 × INTAX® Tx 100F08 1 × INTAX® Tx 100F08	X-axis Y-axis



Y-Z Pick and Place · Z-R Handling

ELAX® Ex · ROTAX® Rxvp

- Vertical axis with weight compensation
- With ELAX® adjustable with selection of spring assembly and with LINAX® adjustable with compressed air

Arrangement	Axes	Function
Y-Z flat	1 × ELAX® Ex 30F20 1 × ELAX® Ex 30F20 1 × Weight comp. Ex 30F20 (0-2kg pull or push)	Y-axis – horizontal, flat Z-axis – vertical Compensation of payload
Z-R	1 × LINAX® Lxu 80F60 1 × ROTAX® Rxvp 28-6T0.04 1 × Weight comp. Lxu 80F60 (0-6kg)	Z-axis – vertical R-axis – rotative, vertical Compensation of payload

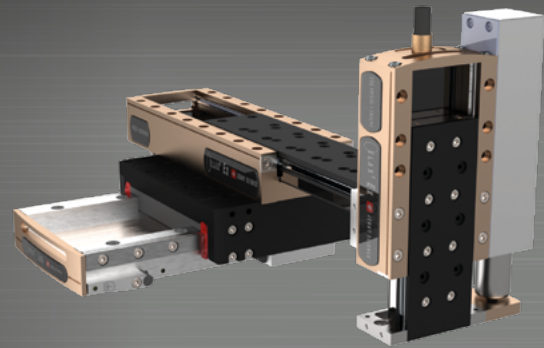
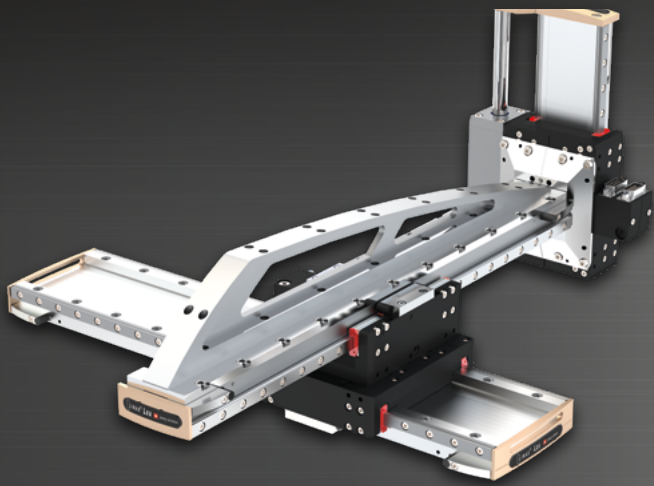

X-Y-Z 3D Handling

LINAX® Lxs/Lxu · ELAX® Ex

- consistent high level of accuracy thanks to low-maintenance and wear-free linear motor axes
- flexible dimensions selectable according to the size and weight of the product

Arrangement	Axes	Function
X-Y-Z flat	1 × LINAX® Lxs 520F60 1 × LINAX® Lxu 320F60 1 × Cantilever armour to LINAX® Lxu 320F60 1 × LINAX® Lxu 80F60 1 × Weight comp. Lxu 80F60 (0-6kg)	X-axis – horizontal, flat Y-axis – horizontal, flat Reinforcement of Y-axis Z-axis – vertical Compensation of payload
X-Y-Z with ELAX®	1 × LINAX® Lxu 520F60 1 × ELAX® Ex 80F20 1 × ELAX® Ex 50F20 1 × Weight comp. Ex 50F20 (0-2kg pull or push)	X-axis – horizontal, flat Y-axis – horizontal, flat Z-axis – vertical Compensation of payload

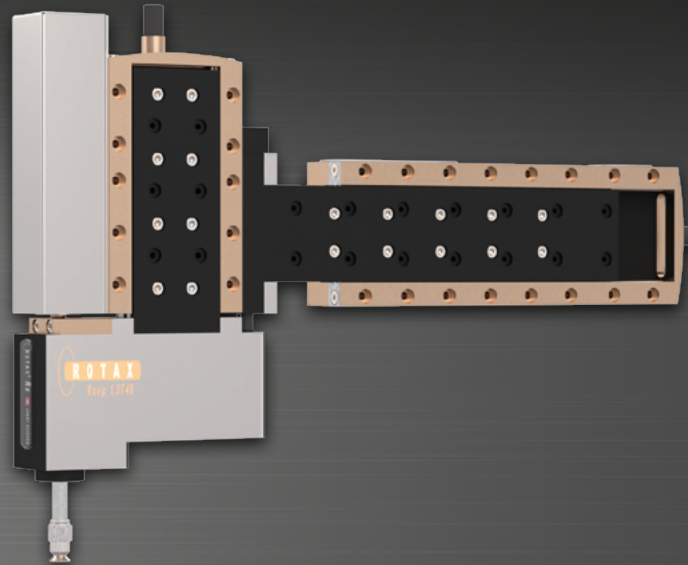

Y-Z-R Pick and Place

ELAX® Ex · ROTAX® Rxvp

- front flange on the slider is ideal for modular systems
- sophisticated, vertical cable and tube feedthrough for ROTAX® rotary motor axes

Arrangement	Axes	Function
Y-Z-R upright	1 × ELAX® Ex 150F20 1 × ELAX® Ex 30F20 1 × ROTAX® Rxvp 28-6T0.04 1 × Weight comp. Ex 30F20 (0-2kg pull or push)	Y-axis – horizontal, upright Z-axis – vertical R-axis – rotative, vertical Compensation of payload

Weight Compensation

If the linear motor axis is used vertically, the slider should not fall when the power is switched off. Vertical weight compensation packages using compressed air or springs are available.

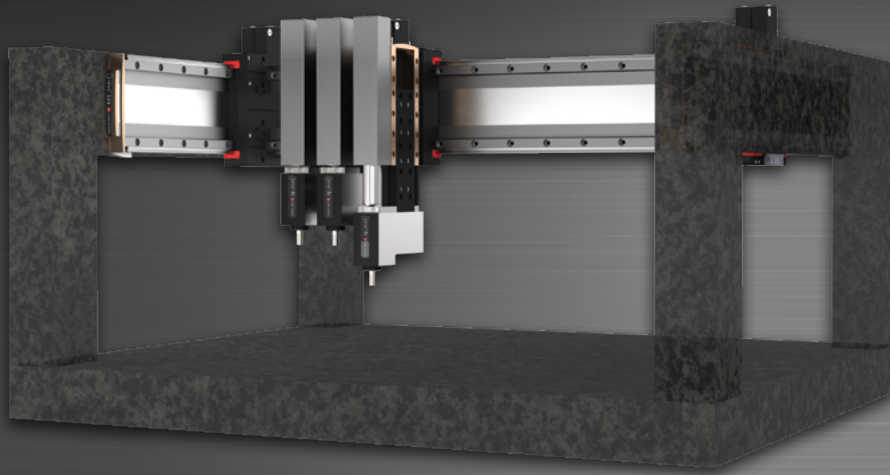

X-Y-Z-R Gantry

LINAX® Lxs · ELAX® Ex · ROTAX® Rxvp

· The Y-axes are arranged in an upright position, leading to minimal space requirement in relation to the strokes.

Arrangement	Axes	Function
X-Y-Z-R upright	1 x LINAX® Lxs 400F60 2 x LINAX® Lxs 520F60 3 x ELAX® Ex 50F20 3 x ROTAX® Rxvp 28-6T0.04 3 x Weight comp. Ex 50F20 (0-2kg pull or push)	X-axis Y-axis (Gantry) Z-axis R-axis Compensation of payload

JENNY SCIENCE AG (Corporate headquarters)

Sandblatte 11
CH-6026 Rain
Phone +41 41 255 25 25
pascal.guinand@jennyscience.ch
ramon.jenny@jennyscience.ch
www.jennyscience.com

SWITZERLAND

German speaking

Jenny Science AG
Sandblatte 11
CH-6026 Rain
Phone +41 41 255 25 25
andreas.hungerbuehler@jennyscience.ch
www.jennyscience.ch

French speaking

AxNum AG
Solothurnstrasse 142
CH-2504 Biel/Bienne
Phone +41 32 343 30 60
aeby@axnum.ch
www.axnum.ch

GERMANY

Jenny Science GmbH
DE-77652 Offenburg
Phone +49 (0)160 501 42 21
josef.jogerst@jennyscience.de
www.jennyscience.com

North-East

Robert Frank
Phone +49 1 517 011 14 57
robert.frank@jennyscience.de

South-West

Felix Hertweck
Phone +49 1 515 218 33 80
felix.hertweck@jennyscience.de

South-East

Marcus Hartwagner
Phone +49 1 515 547 76 33
marcus.hartwagner@jennyscience.de

Western part - Postal Codes: 32-33, 40-52, 58-59

Conway Nederland BV
De Greune 21a
NL-7483 PH Haaksbergen
Phone +31 53 574 32 39
hermanpit@conwaynederland.nl
www.conwaynederland.de

FRANCE

Liaison Office Jenny Science AG
F-51100 Reims
Phone +33 (0)6 40 24 42 13
frederic.menu@jennyscience.ch
www.jennyscience.com

ITALY

Smart Automation S.r.l.
Via Redipuglia, 8
IT-20010 Bareggio (MI)
Phone +39 02 902 60 226
massimiliano.manfredi@smartautomation.it
www.smartautomation.it

 www.linkedin.com/company/jennyscience

Let's do business!

We are working for you worldwide.



SWEDEN

Servotronic AB
Redaregatan 2
Box 155
SE-731 24 Köping
Phone +46 221 137 60
leif@servotronic.se
www.servotronic.se

NETHERLANDS · BELGIUM

Conway Nederland BV
De Greune 21a
NL-7483 PH Haaksbergen
Phone +31 53 574 32 39
hermanpit@conwaynederland.nl
www.conwaynederland.nl

AUSTRIA · HUNGARY

next system Vertriebsges.m.b.H.
Strohbogasse 4
A-1210 Wien
Phone +43 1 33166 155
stephan.albrecht@nextsystem.at
www.nextsystem.hu

SPAIN · PORTUGAL

AT Engineering S.L.
C\ Lope de Vega, 22-24
08005 Barcelona
Phone +34 93.356.80.58
carlos.gordo@at-engineering.es
www.at-engineering.es

UNITED STATES OF AMERICA

Jenny Science US LLC
3337 Ivey Creek Road
Maiden, NC 28650
Phone +1-828 417 0743
sales.us@jennyscience.com
www.jennyscience.com

Arizona · California · Nevada

Contour Motion, Inc.
357 Piercy Road
San Jose, CA 95138
Phone +1-408 201 2345
raleigh@contourMotion.com
www.contourmotion.com

Illinois · Indiana · Wisconsin

Gaumont & Cella Inc.
150 S. Washington St.
Suite A-11
Carpentersville, IL 60110
Phone +1-847 702 9506
ericv@g-c-inc.com
www.g-c-inc.com

Minnesota · Wisconsin

Machine Automation Products
10744 Yellow Pine Street
Coon Rapids, MN 55433
Phone +1-763 757 0198
awilliams@machineautomationproducts.net
www.machineautomationproducts.net

 www.youtube.com/user/JennyScienceAG

CANADA

Jenny Science US LLC
3337 Ivey Creek Road
Maiden, NC 28650
Phone +1-828 417 0743
sales.us@jennyscience.com
www.jennyscience.com

MEXICO

Jenny Science US LLC
3337 Ivey Creek Road
Maiden, NC 28650
Phone +1-828 417 0743
sales.us@jennyscience.com
www.jennyscience.com

CHINA

Beijing JingZhuBoDa Technology Co., Ltd.
Room 515 East Wing, Donggang Xinzuo,
No 56 Fuqian Road, Nanfaxin, Shunyi,
Beijing, 101399
Phone +86 10 89492998
li.xin@bjzxbd.com
www.bjzxbd.com

SOUTH KOREA

M2Plus
#C-802, 807, Gwangmyeong SK Techno Park,
60 Haan-ro, Gwangmyeong - si,
Gyeonggi-do, South-Korea
Phone +82 2 2083 1612
gh.choi@m2plus.kr
www.m2plus.kr

SINGAPORE

Plant & Mill Supplies
4, Loyang Lane, #05-02
Singapore (508914)
Phone +65 65 42 42 11
thteong@pmsupplies.com
www.pmsupplies.com

THAILAND

PMC Technology Co., Lt
99/359 Moo.5, Tambon Bang Krang,
Amphur Muang Nonthaburi, Nonthaburi 11000
Thailand
Phone +66 2108-6041
thteong@pmsupplies.com
www.pmc-technology.com

MALAYSIA

Plant & Mill Motion Control Sdn Bhd
Wisma Malvest, Room 2, 20C, Jalan Tun Dr. Awang
11900 Bayan Lepas, Penang
Phone +604 645 1861, 644 8369
thteong@pmsupplies.com
www.pmsupplies.com

 www.facebook.com/Jenny-Science-AG-110235627336972